

Analysis of technologies for handling liquid radioactive waste. Lessons learned from implementation at Ignalina NPP



KNOWLEDGE PRODUCT

Site: IGNALINA NPP

10/09/2021

Title	Analysis of technologies for handling liquid radioactive waste. Lessons learned from implementation at Ignalina NPP
Developed by	INPP (Ignalina NPP)
What is the goal?	<p>This document aims at providing practical advice to EU decommissioning operators who need to decide between technologies for managing liquid radioactive waste (LWR)</p> <p>It also presents INPP's experience regarding the preparatory works for the installation of LRW treatment facilities and operation</p>
Who may benefit?	<p>Decommissioning operators that are scouting LRW technologies.</p> <p>Decommissioning operators that need to change, improve, or optimize the operation of LRW cementation facilities.</p>
What will you learn?	<p>Users of this project will learn from INPP's experience in the selection of adequate technologies for LWR management.</p> <p>They will also gain concrete examples, tips, recommendations, lessons learned, and good practices related to the optimization and operation of LRW cementation facilities.</p>
About this knowledge product	<p>This knowledge product is presented in the form of a lessons learned report. Lessons learned, recommendations and tips have been collected by INPP throughout the document.</p> <p>Annex I include a set of templates that tackle risks, precautions, and tips for optimized LWR Cementation Facility design and operation.</p>



Knowledge Product KP-03

Title: Analysis of technologies for handling liquid radioactive waste. Lessons learned from implementation at Ignalina NPP
Type: Lessons Learned Report
Produced by: INPP

TABLE OF CONTENTS

TABLE OF CONTENTS	2
1. ABBREVIATIONS	3
2. OBJECTIVE	3
3. VALUE FOR USERS	3
4. CONTEXT	4
4.1. General Status of decommissioning activities	4
4.2 Historic LRW management at INPP	5
4.3 Current Status.....	5
4.4 Upcoming works	6
5. TECHNICAL CHALLENGE.....	6
6. ANALYSIS OF TECHNOLOGIES FOR LWR HANDLING	7
6.1 Selection Criteria	8
6.2 Technology Benchmark	13
6.3 Lessons learned from the analysis	14
7. APPLICATION OF A LRW CEMENTATION PROCESS AT INPP	17
7.1 Overview of the LWR cementation process. Current situation.....	17
7.2 The LRW Cementation Project of INPP	18
7.3 Lessons Learned from the application of LRW cementation process at INPP.....	20
8. CONCLUSIONS	21
9. FINAL RECOMMENDATIONS	22

INDEX OF FIGURES

<i>Figure 5-1. The construction works were performed by local contractors' organizations under separate contracts with INPP in less than 1 year.</i>	16
<i>Figure 5-2. 1250 vibropiles were driven under the foundation slab. The foundation slab was concreted continuously for 10 days during the cold season.</i>	16

1. ABBREVIATIONS

NPP	Nuclear Power Plant.
INPP	Ignalina Nuclear Power Plant.
LNPP	Leningrad Nuclear Power Plant.
IAEA	International Atomic Energy Agency.
LRW	Liquid Radioactive Waste.
SA	Surfactants.
RW	Radioactive Waste.
RS	Radiation Safety.
DW	Drain Water.
TS	Technical Specification.
ESEF	Energy-saving evaporation facility.
EDR	Dose of gamma radiation.
EU	European Union.

2. OBJECTIVE

This document presents the experience and lessons learned by Ignalina Nuclear Power Plant (INPP) in the analysis and application of Liquid Radioactive Waste (LRW) technologies during the decommissioning program of INPP Unit 1 and 2 and auxiliary facilities.

The overall goal is to convey relevant knowledge to other European Union (EU) decommissioning operators to support their own LRW activities, with a focus on:

- The selection of technology for LRW treatment.
- The preparatory works for the installation of LRW treatment facilities.
- The operation of LWR facilities

3. VALUE FOR USERS

Users of this product will:

- Deepen their knowledge of LRW treatment methods.
- Understand the advantages and disadvantages of different methods of LWR treatment, based on INPP's experience.
- Improve their ability to make smarter decisions related to the selection and application of LWR technologies and facilities.
- Acquire practical knowledge regarding the preparation of technical specifications, including examples of criteria that are relevant for the construction of cementation facilities.
- Learn from the experience of INPP in the preparatory works and design modifications of a Cementation facility.
- Gain access to 15 years of INPP's experience in the operation of a Cementation Facility.
- Become aware of the importance of building an integrated team by engaging and coordinating technologists, IT specialists, Operations & Maintenance personnel, R&D and laboratory specialists, Radiation Safety, etc.

- Improve their confidence to achieve organizational results, using the experience, lessons learned, and recommendations collected in this document.

Why this experience is relevant for INPP but also for other decommissioning operators:

- Typically, nuclear power plants accumulate large amounts of radioactive waste, which are stored in huge tanks. INPP's experience can be used to solve similar problems with the handling of LRW in other facilities.
- Salt solutions (concentrate) can be cemented without any special problems, although it is necessary to consider the requirements (criteria) for the quality of packages, cement compound (compressive strength, leaching of ^{137}Cs , frost resistance, checking the conditions of the alkali-silicate reaction, the effect of the used cement grades, powder clays, plasticizers). The considerations and tips collected in this document may help other operators with similar necessities.
- The method of dosing ion-exchange resin and perlite into the mixer, selected by the project, is a complex technological operation. A sufficiently accurate, even feeding of LRW into the mixer is required. This requires ensuring that the resin and perlite are "held" in suspension during dosing. Besides of that, perlite is a very abrasive material. There are several good practices and recommendations that can convey practical solutions to other operators facing the same issues with dosing.

In short, INPP's experience and lessons learned provided useful knowledge for the treatment of 3 types of waste, performed separately and jointly. The experience can be used in simplified projects for treatment, depending on the volume of waste and its composition.

The approaches used in INPP's Project can assist in the implementation of similar technologies in other sites.

4. CONTEXT

4.1. General Status of decommissioning activities

The Ignalina Nuclear Power Plant (INPP) contained two Soviet-designed RBMK-1500 water-cooled graphite-moderated channel-type power reactors. Unit 1 began operation in December 1983 and was shut down on December 31, 2004. Unit 2 began operation in August 1987 and was shut down on December 31, 2009.

Ignalina NPP decommissioning project includes decommissioning of Unit 1 and 2 and auxiliary facilities. The process is divided into two phases. The first phase started in 2004 and continued until 2013. The second phase was scheduled for 2014–2037. By 2038, the site of two reactors should be ready for re-use ("brownfield").

Liquid Radioactive Waste (LRW) solidification units were used during INPP operation:

- Since 1987, a plant for bituminization of the concentrate with activity of 10^{-5} – 10^{-4} Curie/litre.
- Since 2006, an installation for cementation of ion-exchange resins (IER) with activity of 10^{-2} – 10^{-1} Curie/ litre.

4.2 Historic LRW management at INPP

After the shutdown of the power units, the specific activity of ^{137}Cs in the concentrate, associated with the handling of spent fuel, increased by more than 10 times. In addition, due to the program of reducing the use of chemicals, the amount of the concentrate has decreased.

To optimize the process of solidification of LRW of all types (granular IER, concentrate, Perlite), research and selection of recipes were carried out:

- Brand of Portland cement or slag cement.
- Bentonite grade.
- Share of granular IER.
- The amount of concentrate and its salt content.
- Amount of Perlite pulp.
- Possibility of alkali-silicate reaction.

The nuclide vector of the cementing unit was developed for the updated recipe. As a result, from 2020:

- The fire-hazardous bituminization units, the warehouse of pure bitumen was taken out of operation.
- The delivery of the bitumen compound with increased specific activity of ^{137}Cs for storage to the canyons of bld.158 has been stopped.
- An optimal recipe has been developed for joint processing of perlite pulp, concentrate and IER without increasing the final disposal volume at the cementation plant.
- The compound is packed in updated standard barrels with an inner polyethylene liner, which, while reducing the cost, has led to increased resistance of the package to the aggressive radioactive environment of the compound.

4.3 Current Status

All types of Liquid Radioactive Waste (LRW) generated at INPP are received, stored, and treated at INPP site.

- Evaporation (distillation):
 - INPP has two evaporation facilities, each one with a capacity of 30 m³/hour.
 - These facilities are used for the treatment of water received during emptying of equipment, solutions after regeneration and decontamination based on HNO₃ and NaOH, water received during dismantling, and water from special laundry (with a high content of surfactants).
 - Salt content in the treated water is up to 1 g/l.
 - Evaporation up to 300-350 g/l (high-salt concentrate solutions).
- Bituminization:
 - INPP had two facilities, each one with a capacity of 500 kg/h for evaporated water, the treatment of high-salt concentrate solutions (300–350 g/l), salt filling up to 40% (mass).
 - Capacity to treat 19,400 m³ of concentrate
 - 14,400 m³ of bitumen compound was obtained.
 - Decommissioned since 2020.

▪ Cementation:

- Since 2006, an installation for cementation of ion-exchange resins (IER) with activity of 10^{-2} 10^{-1} Curie/liter.
- Ion exchange resin, perlite, sediments, salt concentrates up to 300 g/l.
- The capacity according to the initial project is 450 m³/year, the achieved capacity is 300 m³/year.

4.4 Upcoming works

- It is planned to install the Energy-saving evaporation facility (ESEF) equipment for LRW treatment during the decommissioning period (the project will ensure: the drain water amount decrease, the heating steam and cooling water usage rejection, the modern control systems installation for technological processes).
- It is required to upgrade the Cementation Facility (due to the equipment ageing – 15 years of operation, and incompatibility of the replaced units with the software product).
- Development and implementation of a "new" (fourth) recipe for cementing high-salt solutions, further research is required.

5. TECHNICAL CHALLENGE

After the rejection of the bituminization technology of spent resins and perlite used at the project facility, INPP needed to select an appropriate technology to treat LRW.

INPP uses granular ion-exchange resins and filter aid (Perlite) for water purification and waste treatment. The layered mixture of the used resins and filter aid is temporary stored in the tank under water. The annual quantity of the waste generated at two INPP units was estimated to be 100 m³.

Also, the mixture of a filter aid and solid particles sediments, deposited from evaporator concentrate, is collected in the similar tank. The annual quantity of the waste is around 25 m³. The used resins, filter aid and sediments are referred to as Radioactive Waste.

INPP technical challenge was to develop a Radioactive Waste Solidification Facility which shall be able to perform:

- homogenizing, sampling, characterization, and transportation of radioactive waste.
- cement solidification of radioactive waste.
- manufacture and supply of containers for radioactive waste.
- handling, transportation, and temporary storage of radioactive waste packages.

The Radioactive Waste Solidification Facility shall include the following systems and equipment:

- Cementation Facility

The selection of this technology is addressed in section **6**

Cementation Facility is intended to solidify a radioactive waste (at least 450 m³ radioactivity waste per year) into concrete with subsequent packing of the solid mixture as a waste package) The Cementation Facility shall include the following main components:

- Waste mixing system and mixed waste transportation system.
- Dry component unit (storage reservoirs for cement and dry chemical additives necessary for cement solidification process).
- Monitoring and control system (for control of all technological process and equipment).
- Radiation protection system.

▪ Waste Containers

The weight, volume, shape, and construction of the container shall optimize the solidification process and the manufacturing, handling, transportation, temporary storage, and disposal of containers. Waste package shall meet the long-term stability and barrier function.

▪ Waste package temporary storage.

The capacity of temporary storage (70x120m) shall be sufficient to store waste packages produced during 10-year operation of the Cementation Facility (6 000 m³ total of raw radioactive waste). The temporary storage design shall store waste package during 60 years after the Cementation Facility commissioning.

▪ Transportation system

The transportation system shall include all necessary lifting devices, cranes, vehicles, and appropriate radiation shielding (transport container).

6. ANALYSIS OF TECHNOLOGIES FOR LWR HANDLING

Following the rejection of the bituminization technology of spent resins and perlite used at the project facility, an analysis of possible technologies was carried out: Bituminization, cementation, incineration, pyrolysis, Torch Plasma, curing in polymerization resins, selective sorption release of ¹³⁷Cs and ⁶⁰Co, decomposition by bacteria.

Based on the composition of the 50% inorganic perlite and salt sediment, volume reduction methods proved to be ineffective. The bituminization method used at the existing facility was rejected due to equipment technology problems and high activity of the spent resins.

Cementation instead of bituminization has several disadvantages:

- Leaching of ¹³⁷Cs from the cement compound is higher.
- The volume for the disposal is increased.
- Limiting the amount of salts in the cement compound due to the deterioration of the strength properties.
- Increased possibility of alkali-silicate reaction (yellow gel)/

Cementing of granular IER has limitations because of the quantity on the physical properties of the compound (volume change - "breathing" of IER). To reduce the amount of spent granular IERs, powder IERs are used at the INPP.

The accumulated slurry of the spent Perlite is well processed by means of the cementing method, but there is a limitation on the amount of Perlite included in the cement matrix due to the presence of many pores. Under certain circumstances, free moisture is released from the pores of Perlite, which appears on the surface.

In 1994, an open pre-qualification tender was held to determine the method and technology for solidifying radioactive waste. Based on the results, a method of cementation was selected and a list of potential bidders for a closed tender was determined. Based on the technical proposals of the bidders in this tender, a Technical Specification was developed and agreed with the Lithuanian regulatory authority for the procurement of the service for the implementation of a radioactive waste cementation facility.

The experience with cementation facilities of Ringhals (Sweden), Japan, Great Britain, France, Germany, Belgium, Spain, Russia, and Ukraine was studied. The tender was finally held in 2001.

Other technologies are being analysed by INPP moving forward. An energy-saving evaporation facility (ESEF) is currently at the stage of the tender.

6.1 Selection Criteria

General Criteria

The proposed technology should:

- Be "embedded" into the existing complex.
- Take into account "local" possibilities.
- Be feasible in terms of the possibility of modernization of existing building structures.
- Maximize the use of existing equipment, the use of existing fencing structures and protection from ionizing radiation, and the possibility of performing construction and installation work without increasing dose rates for personnel.
- Minimize dose rates during operation and maintenance
- Maximize automation, remote monitoring, and control of the process.
- Facilitate the quality control of the received product and the execution of periodic inspection of the packages.

Technology

The evaluation and comparison of the tender proposals was carried out on the basis of the requirements of the tender documents for the technical, commercial and financial parts. The technical proposals were evaluated by experts according to the following criteria:

- Removal of radioactive waste from storage tanks to the Cementation Facility.
- Arrangement of the equipment for the Cementation Facility
- The scope of construction work for the storage facility.
- The proposed technology and its technical acceptability at INPP.
- The scope of modifications of the existing rooms, buildings and structures.

- Construction of a container (package) for cemented waste.
- Licensing support, the scope of supervision and technical support services.
- Process control, degree of automation, placement of the monitoring and control equipment.
- Provision with the control, measurement and registration means, process monitoring (RS).
- Training of the personnel.

The technology should provide:

- Full automation of the cementation process, preparation of dry reagents, transfer of packages inside the facility, closure of drums, characterization of packages.
- The possibility to convert some operations to manual / remote control (this does not apply to the cementation process itself).
- Remote control and monitoring of the cementation process parameters.
- Achievement of the appropriate quality of cement compound.
- Usage of appropriate grades of cement, powder clay, plasticizer.
- Mechanical resistance of the equipment.
- Removal of LRW from huge storage tanks and transportation to the Cementation Facility.
- Usage of a small volume mixer with the ability to quickly replace it.
- Usage of direct-flow fittings.

Packaging

Waste container design should meet the following requirements:

- Maintain the integrity throughout sixty (60) years of temporary storage on INPP site.
- The possibility to transfer the waste package from the on-site temporary storage to the regional repository after sixty (60) year storing on site.
- The weight, volume, shape and construction of the container should optimize solidification process and manufacturing, handling, transportation, temporary storage and disposal of container.
- The limit of the radiation dose rate on the waste package surface must not exceed the level of 1 Rem/h. The dose rate at 1.0 m distance from waste package surface must not exceed 0.1 Rem/h. The radioactive dose rate on the transport container during the transportation must not exceed 0.2 Rem/h.
- Waste package must fulfil the long-term stability and barrier function.

All characteristics of waste package should be set considering to mechanical strength, leachability, and other properties of importance for transportation, temporary storage and final disposal.

The container design should include all features necessary for its handling, loading and transportation.

The container should retain its integrity under potential fire conditions and immersion in water to avoid dispersion of activity.

Main requirements:

- Small in size.
- The possibility of reliable characterization.

- The universality for handling.
- The possibility for inspection.
- The possibility of long-term storage.

In the case of INPP, the main container is a standard 200-litre drum made of carbon steel, which is painted inside and outside. The lid on the drum is fixed by means of a ring tightened with a bolt. The drum is classified according to IAEA standards as an IP-II container. The filled drums are placed in the storage container.

Level of automation

In INPP, the technological process and equipment operations are remotely controlled and monitored from the Cementation Facility Control Desk (CFCD). The major operations of the facility are performed automatically and controlled by programmable controller at the CFCD. The CFCD provides the control for the sequence of operations and correct functioning of the Cementation Facility. The Cementation Facility is equipped with visual inspection systems of the major process stages including monitoring the level of waste in the container.

A good level of automation may provide the following advantages:

- The possibility to convert some operations to manual / remote control (this does not apply to the cementation process itself).
- Remote control and monitoring of the cementation process parameters.
- Full automation of the cementation process, preparation of dry reagents, transfer of packages inside the facility, closure of drums, characterization.

ALARA considerations

The Cementation Facility must meet ALARA principle to minimize dose rates of personal. Some good practices that help achieve this are:

- Process remote control and operation.
- Equipment decontamination.
- Reliable sealing of rooms and equipment.
- Radiation dose monitoring at all process stages.
- Dose rate monitoring of the waste packages before transportation to the temporary storage.
- Appropriate shielding arrangements for the waste packages in the respect of their transportation to the storage.
- Appropriate shielding of equipment and waste packages storage.
- Radiation monitoring of ventilation system to detect aerosols.

As an example, all rooms where Cementation Facility is installed in INPP are equipped with radiation alarm system. All alarms are displayed on all room entries.

The Temporary storage design should meet applicable radiation protection requirements:
In the case of INPP

- During normal operation and potential accidents, the estimated average doses to the relevant critical groups of members of the public that are attributable to practices doesn't exceed the following limits:
 - An effective dose of 1 mSv in a year.
 - In special circumstance, an effective dose of up to 5 mSv in a single year provided that the average dose over five consecutive years does not exceed 1 mSv per year.
 - An equivalent dose to the lens of the eye of 15 mSv in a year.
 - An equivalent dose to the skin of 50 mSv in a year.
- The dose to any worker during normal operation doesn't exceed 14 μ Sv per hour inside the storage and 1.2 μ Sv per hour outside the storage.
- The occupational exposure of any worker controlled that the following limits be not exceeded:
 - An effective dose of 20 mSv per year averaged over five consecutive years.
 - An effective dose of 50 mSv in any single year.
 - An equivalent dose to the lens of eye of 150 mSv in a year.
 - An equivalent dose to the extremities (hands and feet) or the skin of 500 mSv in a year.

Also:

- The dose rate of the waste package prior to its transportation to the temporary storage are measured, as well as the nuclide content of radioactivity waste are determined by means of gamma-spectrometry.
- The limit of the radiation dose rate on the waste package surface does not exceed the level of 1 Rem/h. The dose rate at 1.0 m distance from the container does not exceed 0.1 Rem/h (requirement for transportation).
- Each container has a label that uniquely identifies it and allows it to be correctly recognized and recorded during waste conditioning, storage, handling, transportation and disposal.
- The process equipment design meets the goal that contamination of the surface waste packages is avoided.
- Waste package fulfills the long-term stability and barrier function.
- Waste package retains its integrity under potential fire conditions and immersion in water to avoid dispersion of activity.

Recommended technical solutions and implemented measures at INPP to improve ALARA:

- Equipment and pipelines containing LRW are located in rooms with appropriate biological and organizational protection.
- Extraction, transportation and preparation of LRW is carried out remotely with the control of the parameters of operations (flow rate, pressure, level), monitored visually by TV cameras.
- The small volume mixer is used – 5 litres.
- The possibility of replacing worn-out equipment has been implemented.
- Filling, moving, closing, characterization is performed automatically.
- The package is placed into the storage container (for additional shielding of packages).

Cost

Typical costs are:

- Cost of the design and supply of the equipment for the Cementation Facility.
- Cost of the equipment transport scheme.
- Cost of the equipment temporary storage.
- Cost of credits (if necessary, to finance the project).
- Operation and maintenance costs

As an example, the current demand of the operating complex at INPP for a year is:

- Containers – 300 units
- Drums – 2500 units
- Cement – 450 tons
- Bentonite – 45 tons
- Plasticizer – 5 tons

The cost of the equipment for characterization at INPP is 250,000 euros

Operation and Maintenance

Maintenance is a key aspect of technology selection. Periodic maintenance may be optimized by using statistics collected during the packages operating time, monitoring and evaluating equipment operation parameters, including the comparison with external operating experience.

Some daily works on the equipment maintenance, based on INPP's experience, are:

- flushing the mixer,
- cleaning the dry reagents inlet,
- TV cameras, drums motion sensors, and drums closing unit,
- 2 tons crane inspection,
- new drums installation,
- crimp rings, lids.

Training

Another aspect that must be considered when selecting a technology is the associated training and qualifications.

Some of the trainings that were developed in INPP:

- Designer training with the issuance of certificates.
- Training on the programs regarding the use of IT products.
- Overhead crane operator training.
- Training on the new program regarding the package's characterization.
- Development of operating instructions.
- Training on the new modifications.

Other Criteria to be considered

- Removal of LRW from huge storage tanks and transportation to the Cementation Facility (150 meters).
- The possibility of LRW averaging in storage tanks.
- Preparation of LRW for cementation: the possibility of removing excess water and taking a representative sample of LRW.
- During the cementation – maintaining homogeneity, measuring the amount of LRW and its even dosing into the mixer.
- Control of drum filling with cement compound.
- Easy laying of the cement compound.

6.2 Technology Benchmark

Cementation technologies can be divided into 2 types:

- Technology of a continuous cementation process,
- Technology of a periodic cementation process

The continuous process, firstly, allows the use of containers of different volumes, and, secondly, it has a reserve in terms of packaging capacity. The periodic process has the following disadvantages:

- The mixer volume shall be a multiple of the container volume, which limits the choice of the container volume,
- The capacity of the process is determined by the mixer volume and the time required to prepare each portion of waste.

Key aspects to support other operator in selecting cementation technologies

- Full automation of the cementation process, preparation of dry reagents, transfer of packages inside the facility, closure of drums, characterization.
- The possibility to convert some operations to manual / remote control (this does not apply to the cementation process itself).
- Remote control and monitoring of the cementation process parameters.
- The possibility to change / supplement the algorithm of cementation.
- Maximum use of existing equipment, fencing structures, protection against ionizing radiation.
- The possibility of preparing for cementation a new volume of LRW, controlling the composition and averaging of LRW in storage tanks.
- Preparation of LRW for cementation: the possibility of removing excess water and taking a representative sample of LRW.
- During the cementation – maintaining homogeneity, measuring the amount of LRW and its even dosing into the mixer.
- Control of drum filling with cement compound.
- Easy laying of the cement compound.
- Small volume of the mixer.
- Easy replacement of worn-out equipment (ALARA) and their low cost (use of standard wear parts – equipment elements).
- Radiological characterization of packages with the necessary reliability and conservatism.
- The possibility to inspect and control the quality of manufactured packages and cement compound.
- Joint cementation of concentrate (salt concentrates), resin and perlite.
- Absence of "hot" spots on the package (due to the homogeneity of the paste and the relatively small volume of the package).
- In the event of an accident (a drum falling, the conveyor's disconnection and/or its malfunction), 200-litre drum (350–400 kg) is relatively easier to remove, place, roll, push than a heavy container (more than 1 tonne).
- Due to a package's weight of 350–400 kg, no special (additional) reinforcement of the building structures is required.

6.3 Lessons learned from the analysis

Design

- Equipment interfacing with existing INPP plant installations must be designed to ensure optimum results of the integral system, of which the equipment is a part.
- Make sure the supplier uses standard products and components to achieve optimum results.

Contractual aspects

The scope of supply of the supplier should include:

- Design, manufacture, supply and delivery of the Cementation Facility including auxiliary systems and special tools and spare parts.
- Delivery option for equipment.
- Operation and maintenance training of INPP staff.
- Supervision during erection, installation, testing and commissioning.

Factory acceptance test (FAT)

- Operators' representatives should witness factory acceptance test (FAT) at the supplier's premises
- Prior to testing, ask suppliers to submit the test procedures and acceptance criteria for information.
- Comment on the procedures and criteria completeness and adequacy
- Ensure that it is the supplier's responsibility to accept or withdraw these comments.
- Include the submission of a FAT report for the operator's approval.

Site acceptance test (SAT)

- The SAT must demonstrate fully that once the Cementation Facility is installed and the Temporary storage and the Transportation system are constructed, the Cement solidification facility and its components met, independently and as an integrated system, the requirements of the contract.
- The SAT should be performed following completion of installation and construction of all the facility components.
- Operators' personnel may perform the test under supplier supervision.
- The supplier should submit to the purchaser for approval the SAT procedures and acceptance criteria of the installed cement solidification facility installed.

TIP

The SAT was carried out at INPP in two stages:

- The full simulation of the solidification processes using radioactive waste imitator, including transportation of empty container to the Cementation Facility and waste package to the temporary storage.
- The full solidification cycle using real radioactive waste in real operating conditions including transferring of the radioactive waste to the Cementation Facility. At this stage testing of the radiation protection system were most important

The second stage of SAT was performed after satisfactory completion of the first stage. The supplier submitted a SAT report to the purchaser for approval.

Construction: interaction and coordination

Construction of the temporary storage building (one-storey three-bay building 120x70, equipped with auxiliary systems (ventilation, heating, special sewerage, drainage), necessary reconstruction of existing structures and installation of equipment was organized at the INPP and performed by contractors' organizations under the supervision of the supplier.

The INPP specialists, having evaluated the sketches of the containers' temporary storage facility, provided during the tender, came to the conclusion that from the point of view of performing construction and installation works, the most acceptable is the storage building constructed from prefabricated reinforced concrete structures, since such a building, due to the unification of the reinforced concrete elements, is installed approximately 1.3–1.5 times faster than the same volume building made of monolithic reinforced concrete, and the labour costs for its construction

are much less. The foundation slab and external walls of the building shall be made of heavy monolithic reinforced concrete.



Figure 5-1. The construction works were performed by local contractors' organizations under separate contracts with INPP in less than 1 year.



Figure 5-2. 1250 vibropiles were driven under the foundation slab. The foundation slab was concreted continuously for 10 days during the cold season.

Equipment Layout

Rooms of existing buildings may be used to accommodate equipment. In the case of INPP, the following rooms of the building 150 were proposed for this purpose:

- Room 231 – (available area 36x6 m²) – recommended for the placement of the main equipment of the Cementation Facility.
- Room 105 – recommended for the placement of the dosimetric and spectrometric control equipment, this is a place for accumulating empty or filled containers.

- Room 106 – recommended for the placement of the equipment requiring increased protection due to high radioactivity.
- Room 104 – recommended for the storage of empty containers.
- Room 324 – (available area 9x6 m²) – recommended for the placement of control and visual monitoring panel.
- Rooms 125 and 126 with the placed monjus – special tanks used before for displacing liquids by compressed air and used now as buffer tanks are placed.
- The project provides for the equipment placement in the following rooms:
- Room 231 – the equipment of the Cementation Facility, drums monitoring system and bulk reagent storage and dosing unit – occupied area – 54x6 m.
- Room 105 – loading of filled drums into the storage container.
- Room 324 – control panel, electronic cabinets.

Licensing

The contract with the supplier must include clear commitments and deadlines to ensure timely submittal of all documentation required by the operator to meet the requirements of the regulatory body.

7. APPLICATION OF A LRW CEMENTATION PROCESS AT INPP

7.1 Overview of the LWR cementation process. Current situation

The technological process of cementation chosen by the designer is both unique and technologically complex: extraction of waste from large tanks, transportation through the pipeline and preparation of LRW for the cementation, assurance representative sampling of LRW, assurance uniform dosing of the estimated amount of LRW and dry reagents, for example: LRW – 7.5 ± 0.2 kg/min (125 ± 3.0 g/s), cement + bentonite – 160 ± 3 g/s.

During the dosing of LRW it is necessary to take into account the physical properties inherent to heterogeneous solutions: "tendency" to the separation of phases at rest or flow rates below 0.5 m/s, compaction, caking, etc. The accuracy of LRW dosing affects the amount of water required to comply with the calculated ratio to cement and bentonite, the quality of the paste, easy its laying, the degree of filling of the package, the even distribution of waste, the activity in the package, EDR. Besides that, cemented LRW is highly abrasive – filter-perlite, which leads to rapid mechanical wear of the dosing device, unloading device (mixer), fittings.

It took about 10 years to stabilize the cementation process. During this time, more than 25 modifications, changes, improvements in the operation of equipment, software, the algorithm of cementation were implemented. More than 100 compositions of cement compound, nine different powder clays have been studied. The joint cementation of the concentrate with perlite and resin has been started. Currently, the process of LRW cementation is mainly well organized. The fourth recipe for cementation of high-salt concentrates (replacing bituminization) is being considered. The operating personnel are trained, experienced in operation, maintenance and repair. Problems arise, but based on the experience gained, they are solved faster compared to the period of the beginning of cementation.

In the process of setting up the Cementation Facility, changes were made to the LRW feeding and dosing technology, selection of the mixer operating mode, the dosing pump, software and control of the cementing process. Some units and elements have been added, for example: the central control processor has been replaced with a more powerful one, the plasticizer feeding and dosing unit have been added, the vibrator has been added to improve the spillage of dry reagents, the LRW flow meter has been replaced, the ideology of the dosing control system, pilot valves control by pneumatic actuators has been changed, and the new size of drums has been added. During the operation of the facility, some electronic and pneumatic units have been replaced with more modern ones.

As a result of the above, the limit of changes has been reached. In the near future, problems may appear that cannot be solved simply by replacing the defective equipment. For example, the replacement of SIWAREX weighting modules: the currently used model is outdated, the manufacturer does not produce or support it, and the new models are not compatible with the outdated software.

7.2 The LRW Cementation Project of INPP

The INPP project provided for treatment of the concentrate, spent ion-exchange resins, filter-perlite by the bituminization and storage of bitumen compound in compartments, in the INPP building 158. The experience of commissioning works at a similar experimental facility of LNPP showed the unacceptability of this technology for the treatment of spent ion-exchange resins, filter-perlite. In this regard, it was decided at the INPP not to treat spent resins and filter-perlite at the bituminization facility, but to temporarily store them in 1500 m³ tanks under a layer of water.

In the period from 1999 to 2006, taking into account the modern IAEA requirements for radioactive waste management, the modification was implemented to change the bituminization method of spent ion-exchange resins, filter-perlite to the cementation method.

In the period from 1999 to 2001, an international tender was held for the procurement of services for the development of the Project, supply of the equipment for the facility of spent ion-exchange resins, filter-perlite and concentrate sediment cementation.

In 2003 the project of the Cementation Facility was developed and approved by the relevant institutions of the Republic of Lithuania.

In the period 2003–2005, the project on LRW cementation was implemented at INPP. A series of modifications and changes were implemented that may help other decommissioning operators improve their own LRW treatment processes.

Modifications

1. Decision on the use of powder resin as a filtering layer of the precoat cartridge filters, refusal of the use of filter-perlite. The goal is to increase the ion exchange capacity of the resin at the condensate aftertreatment facilities, low-salt water treatment facilities, and to reduce the amount of abrasive waste for cementation.
2. Installation of a filter trap on the dispense of mixed LRW from tanks 1,500 m³ to the Cementation Facility (in the LRW preparation tank). The goal is to retain a large fraction of waste – more than 5 mm.

3. Washing the glass of the video camera that monitors the visual filling of the drum. The goal is to improve the visual control of the drum filling, to reduce the dose rate for the operating personnel.
4. Changing the direction of the LRW flow through the dosing pump.
5. Organization of the second LRW circulation loop by the LRW dispensing pumps through the dosing pump.
6. Installation of a flow meter on the second LRW circulation loop. The goal of modifications 5, 6 and 7 is to prevent "settling" of LRW in pipelines, to ensure the even feeding of LRW by the dosing pump to the mixer, to organize constant mixing of LRW, "unloading" of large capacity LRW dispensing pumps, to control LRW flow through the second loop of LRW circulation.
7. Installation of the vibrator on the unit for spillage dry reagents from the dispenser hopper into the mixer. The goal is to prevent deposits (sticking, caking) of dry reagents on the surface of the dry reagent inlet nozzle into the mixer, and to ensure the even feeding of dry reagents into the mixer.
8. Replacement of the material of the pipeline-insert from metal to a soft insert at the dry reagent dispensing unit from the hopper of the dispenser to the mixer. The goal is to have quick access for cleaning of the dry reagent inlet into the mixer unit, and to prevent the "hard" contact between the dry reagent dispenser hopper and mixer, affecting dry reagents flow readings.
9. Installation of frequency regulation in the power supply circuit of the filling drum vibration motor. The goal is to set up the optimal vibration frequency of the filling drum depending on the level of its filling, and to ensure the levelling of the cement compound, the maximum filling of the drum.
10. Independent from each other regulation of the set flow rates of dry reagents and LRW into the mixer. The goal is to ensure the even feeding of dry reagents and LRW into the mixer.
11. Replacement of LRW transfer pumps KL50S.80.2 with KL50S.80.0. The goal is to ensure an easier start-up of the pumps after 16 hours of downtime (by reducing the length of the screw), and to reduce the dose rates for the operating personnel.
12. Feeding the plasticizer into the mixer. The goal is to ensure the mobility of the cement compound, the easy laying of the compound, to increase the filling capacity of the drum, to reduce the water-cement ratio, to reduce the mechanical wear of the mixer equipment (stirrer, the stator-rotor of the cement compound unloading).
13. Installation of the pinch-valve device at the outlet of the cement compound from the mixer. The goal is to ensure maximum efficiency of washing the mixer and to prevent the "leakage" of the washing solution from the mixer.
14. Modernization of the quick-release joint of the dry reagents screw and the LRW stirrer in the mixer. The goal is to securely connect the two parts of the mixer, quickly remove the stirrer when disassembling the mixer, and reduce dose rates for the personnel.
15. Modernization of the drum closing unit: installation of the compressed air filter, changing the algorithm for gripping the ring and the cover, installation of a stop when closing the drum. The goal is to ensure uninterrupted automatic closing of drums.
16. Installation of frequency regulation in the power supply circuit of the stirrer motor in the feed tank. The goal is to optimize the stirrer's speed, to prevent air entrainment while mixing LRW in the tank, and to ensure the even feeding of LRW into the mixer.
17. Installation of additional fittings on LRW receiving pipelines in the tank of the Cementation Facility, arrangement of an additional pipeline flushing unit in case of its "clogging". The goal is to prevent clogging of pipelines with waste, and if necessary, to perform flushing.
18. Use of SORMITE hard coating on the blades of the LRW stirrer in the mixer. The goal is to reduce mechanical wear, to increase the lifetime of the stirrer.

19. Preparation of the stator for unloading the cement compound from the mixer with the possibility of its "squeezing" by the specially manufactured device (as mechanical wear of the stator-rotor pair occurs). The goal is to restore productivity, to prevent "leakage" of the paste (cement compound) from the mixer, to restore productivity, to increase the effectiveness of the mixer flushing.
20. Modernization of the gripping device of 2 t crane. The goal is to ensure a secure grip of the container lid and drums, manufactured before and after 2020.
21. Compressed air receiver device installation in the pilot valve control circuit of the pneumatic drives for fittings. The goal is reliable control of valves.
22. Installation of a volumetric flow meter on the LRW feeding pipeline from the dosing pump to the mixer. The goal is to ensure the objective control of LRW flow to the mixer.
23. Regulation of the LRW flow into the mixer by the dosing pump depending on the mixer's rotation frequency (preliminary calibration of the flow rate). The goal is to ensure the even flow of LRW into the mixer.
24. Research in the field of application of various grades of cement, powder clay, plasticizer. The goal is to optimize and select the recipe for cementation, to confirm the compliance with the eligibility criteria of the cement compound, the selected recipes, to confirm the recipe for joint cementation of salt concentrates with resin and perlite, and to substantiate the cementation of the high salt concentrates. The research results are documented as Reports (more than 20 researchers), most of which were agreed with the Regulator.

7.3 Lessons Learned from the application of LRW cementation process at INPP

Generic Lessons Learned

- There should be built a team of like-minded people: project owner, technologist, IT specialist, repairman, specialists of the laboratory, RS, construction supervision specialist. It requires confidence, the desire to achieve results, the ability to make decisions.
- There are no "bad" projects. The ability of the team to solve non-standard tasks, the ability to modernize and improve the cementation process and equipment operation.
- The persons making decisions shall have operational experience, the ability to gather and listen to different opinions, to choose the optimal one, the ability to analyse and evaluate the results obtained, the knowledge in this field, the means to achieve the goal.

Process optimization, design modifications, operation, and maintenance

Annex I provide a set of templates describing the main lessons learned, risks and good practices of INPP during the following steps of the LRW cementation process:

- Homogenization
- Transfer
- Water Decanting and preparation
- Transfer to the mixer
- Filling and measuring
- CEMENT AND ADDITIVES
- Radiological Characterization
- Transport
- Storage

Staffing

During the operation of the facility, the following operators are necessary:

-
- for the control of the Cementation Facility,
- for work on the Cementation Facility and sampling,
- for the handling of empty and filled drums,
- for work related to waste homogenization and removal,
- for work at the temporary storage.

Five (5) operators are performing works in pairs in two shifts, the transport driver, the passport documenting technician, the person performing the transportation, laboratory technicians, repair, and IT – by the contractors.

Training specifics

The training program for the customer's personnel consisted of 3 stages:

- during the installation and testing period – the operating and repair personnel were present in the role of observers.
- the theoretical course was conducted before the complex cold tests, the operating personnel performed the equipment tests under the supervision of the contractor
- after completing the complex tests, the operating personnel was certified and allowed to work on their own.

Operating data

Here are some numbers on the operation of the LWR cementation facility:

During the period 2006–2021 over 2,000 m³ of radioactive waste was treated at the facility:

- TW18B01 – 1100 m³ of waste resin and perlite pulp.
- TW18B02 – 400 m³ of concentrate sediment (fine fraction of perlite).
- TW11B03 – 100 m³ of spent granular resin and powder resin pulp.
- TW18B01,02 – 450 m³ of concentrate (salt concentrate from evaporation facilities).

8. CONCLUSIONS

INPP has studied and implemented several technologies to optimize the management of LRW at Ignalina NPP.

This knowledge product conveys technical experience and lessons learned over more than 15 years on how to select, implement and modify LRW cementation technology

The approaches and recommendation collected and shared by INPP Project can assist in the implementation of similar technologies in other sites.

9. FINAL RECOMMENDATIONS

Key factors that can improve the implementation and performance of a LWR cementation facility

- The Project Owner should have an experienced team of specialists with knowledge of accumulated operational waste, who reviewed the technologies and international experience in this field.
- The Project Owner must use a competent organization in the field of RAW treatment technology and commercial matters to develop the technical specification for the facility.
- When evaluating the contractors' bids, a comparative evaluation should be carried out:
 - for the acceptability of the technology,
 - for the cost of project implementation,
 - for operating costs during the planned service life.
- Close cooperation between the owner's team and the contractor facilitates the timely completion of the project within the budget.
- For the selection of recipes, the contractor must provide a program and the necessary equipment to the INPP before the installation of the facility.
- The owner's team, with the support of the contractor, must obtain the operating license and ensure along the remaining lifetime of the LWR process
- Continuous adjustments and improvement of formulations and technology related to changes in the ratio of resin, perlite and salt concentrate, must be taken into account within the project boundary.
- The training program for the customer's personnel may be split in 3 stages:
 - during the installation and testing period – operating and repair personnel present as observers,
 - before the complex cold tests - theoretical course + operating personnel performing tests of the equipment under the supervision of the contractor,
 - after completing the complex tests – certification of operating personnel

ANNEX I

LESSONS LEARNED AND GOOD PRACTICES OF INPP REGARDING THE LWR CEMENTATION PROCESS

HOMOGENIZATION

Resins and perlite have accumulated for 10 years in a tank, the volume of which is 1500 m³ and diameter – d=18 m, with an internal support column under a layer of water. The hatch 0.8x0.8 m have been used for installation of the homogenizing equipment. The tank is filled with 90% radioactive sediment.

During the preparation for operation, airlift systems, pulsation pumps, pneumatic diaphragm pumps, screw pumps, and barbotage were tested. The contractor's proposal to use the standard mixers "flygt" and submersible pumps mounted on a lowered supportive console was the most effective.

Operating experience has shown the correctness of this solution. this solution allows to flush-out the sediment by layers of 1.5–2 m depth and averaging over the entire area of the tank.

The scope of supply also included a mobile device for cleaning the bottom and walls of tanks from sludge equipped with special nozzles. A high-pressure pump supplies the nozzles with water. This device makes it possible to move the deposited waste, which is then pumped out by a submersible pump.

TV cameras and lights are installed inside the tank to control the waste extraction and homogenization device. The control is carried out from the local control panel.

All equipment and pipelines have a flushing system. This technology allows to free the tank from pulp and completely clean its walls and bottom. The waste mixing system provides a homogeneous waste mixture

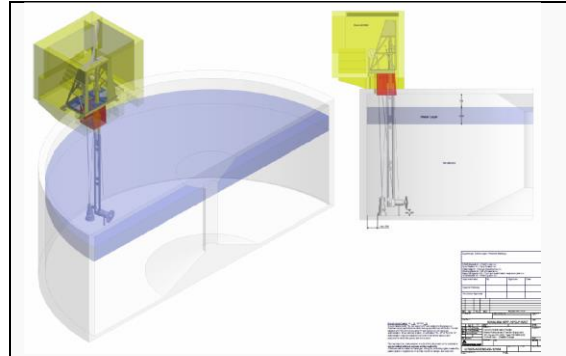
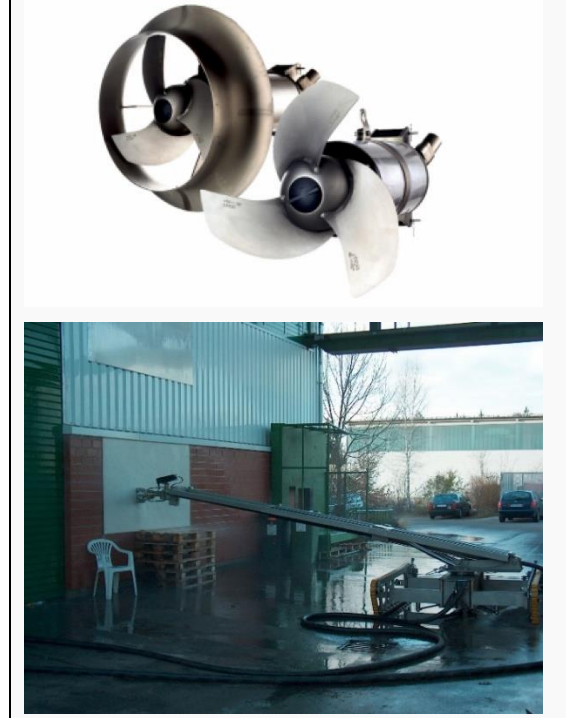

Figure 4-1. Flygt™ Propeller Mixers, With and Without Jet Ring.



CAUTION

You may need to drill the slab of the tanks. This happened during the implementation of the LRW Cementation project of INPP. A square hole of 1x1 m was drilled in the concrete slab of the tanks.

Consider the crane span to plan for the lowering and submerging of the supportive console to the deposited sediment. In the case of INPP, the supportive console needed to be submerged into a depth of 5 meters, while the height of the room ceiling was limited to 3 meters



TIPS

Take advantage of the homogenization testing to validate the other tank cleaning processes

After testing this unit in 2 tanks of INPP, 90% filled with pulp, it was used in projects for cleaning tanks from high-active sediment.

TRANSFER

The following risks can arise:

- the overflowing of the receiving tanks by the "siphon" principle when the pipeline is full (specific location of the equipment and the pulp pumping pipeline).
- pipeline clogging with pulp at a distance of 150 meters
- the organization of a large size particle filtration unit with backwashing.

Decisions were determined following the ALARA principle.

According to the project, an eccentric auger pump was used to transport waste to the Cementation Facility, to which the waste is fed by a submersible pump.

The pumps can handle media containing up to 20% solid particles.



CAUTION

To prevent the clogging in the pipelines, it is necessary to ensure the flow rate and exclude the sedimentation of solid particles



TIPS

The organization of a large size particle filtration unit with backwashing

WATER DECANTING & PREPARATION

The pulp decantation and preparation unit consists of 2 pulp preparation tanks (specially designed tanks have significantly increased the reliability of the facility) and the dosing tank for the entire facility, as well as for the sampling unit.

For the preparation of pulp, the monjus with volume 32 m³ were modified:

- the rotary stirrer was replaced with 2 screw, eccentric stirrers
- the decanting devices with floats were installed
- single screw pumps were installed for the pumping of concentrated pulp
- the vacuum drainage monjus were connected for the emergency pumping of the tank
- ultrasonic devices for water level and sediment level indication were installed into the monjus.

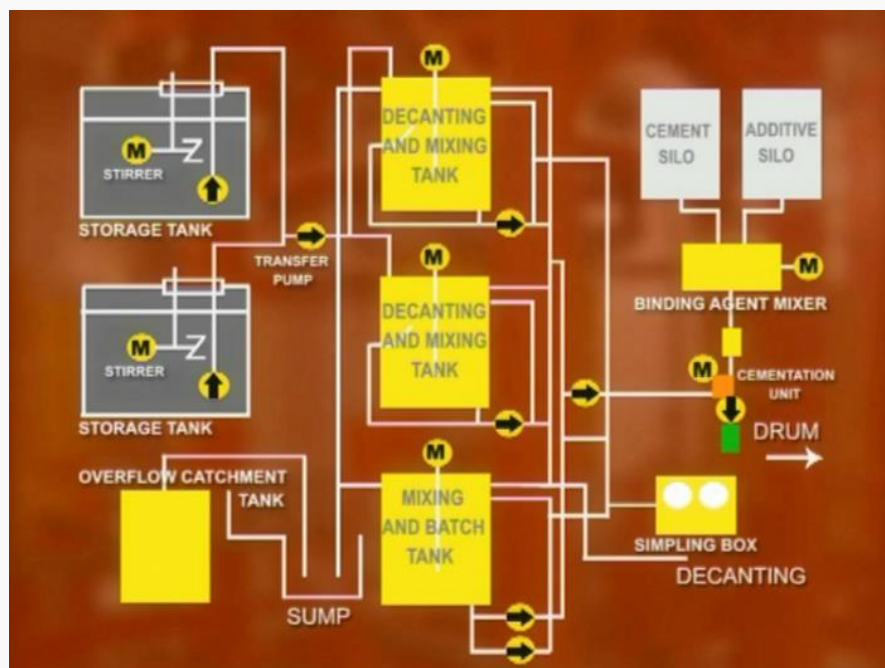

CAUTION

Consider emergency pumping of the tanks to prevent overpressure in the tank in the case of pumps failure hydraulic valve



TIPS

Thus, the treatment of the pulp and the mixture prepared in the required ratios can be performed at the facility

TRANSFER TO THE MIXER

It is necessary to supply the pulp having a constant composition to the dosing pump and mixing unit.

To exclude the clogging of a small diameter (dn20–30 mm) pipelines, a constant flow rate is required

- a recirculation contour was organized to ensure a constant flow.
- at the same time, this contour allowed to ensure the stable operation of the pump supplying the pulp from the monjus.
- the flow meter type changed which is used for the control coriolis type changed to the induction type.
- an additional flow meter was installed on the circulation contour behind the dosing pump.

INPP changed the position of the dosing pump to improve the circulation contour operation and to exclude sediments in the screw pump intake chamber



CAUTION

A constant flow rate is required



TIPS

Set up a recirculation contour

FILLING AND MEASURING

The waste is mixed with the dry components and, using a special pump, the product is poured into a 200-litre drum. The drums are transported to the facility by a conveyor. The lids are removed from the drums before moving it into the starting position. The removed lids are folded into a tray for their exchange.

During filling, the drum is placed on a vibrating table and covered with a special hood to prevent the release of aerosols and splashing of the cement mass. The hood is equipped with an ultrasonic level gauge. The feeding of components into the mixer stops when the pre-set level in the drum is reached.

During the change of drums, a metal sheet is placed under the unloading system to collect the drops. This sheet is covered with a plastic wipe. After contamination, this wipe is removed into an empty drum.

The quality of the finished product is ensured by checking the quality of cement and the accurate dosing of waste and dry components into the mixer.



CAUTION

It is necessary to clean the glass of the video camera that monitors the visual filling of the drum



TIPS

- Installation of frequency regulation in the power supply circuit of the filling drum vibration motor. The goal is to set up the optimal vibration frequency of the filling drum depending on the level of its filling, and to ensure the levelling of the cement compound, the maximum filling of the drum.
- Feeding the plasticizer into the mixer. The goal is to ensure the mobility of the cement compound, the easy laying of the compound, to increase the filling capacity of the drum, to reduce the water-cement ratio, to reduce the mechanical wear of the mixer equipment (stirrer, the stator-rotor of the cement compound unloading).
- Installation of the shut-off device at the outlet of the cement compound from the mixer. The goal is to ensure maximum efficiency of washing the mixer and to prevent the "leakage" of the washing solution from the mixer.
- Modernization of the drum closing unit: installation of the compressed air filter, changing the algorithm for gripping the ring and the cover, installation of a stop when closing the drum. The goal is to ensure uninterrupted automatic closing of drums.
- Installation of frequency regulation in the power supply circuit of the stirrer motor in the feed tank. The goal is to optimize the stirrer's speed, to prevent air entrainment while mixing LRW in the tank, and to ensure the even feeding of LRW into the mixer.
- Use of SORMITE hard coating on the blades of the LRW stirrer in the mixer. The goal is to reduce mechanical wear, to increase the lifetime of the stirrer.
- Preparation of the stator for unloading the cement compound from the mixer with the possibility of its "squeezing" by the specially manufactured device (as mechanical wear of the stator-rotor pair occurs). The goal is to restore productivity, to prevent "leakage" of the paste (cement compound) from the mixer, to increase the effectiveness of the mixer flushing.

CEMENT AND ADDITIVES

The dry components unit consists of two storage tanks for cement and additives (bentonite). The cement and additives stock are planned for 2 weeks of operation of the facility. From the storage tanks, cement and additives are fed to the dry component's mixer by auger conveyors. From the dry component's mixer, under the action of gravity, the dry mixture is fed for dosing into a buffer tank in the volume required to fill one drum and is dosed into the mixer using a special nozzle. A specially designed, continuously operating mixer is used for the cementation of waste.



CAUTION

All equipment of dry component unit has the filters installed to prevent dust formation



TIPS

Installation of the vibrator on the unit for spillage dry reagents from the dispenser hopper into the mixer. The goal is to prevent caking of dry reagents on the surface of the dry reagent inlet nozzle into the mixer, and to ensure the even feeding of dry reagents into the mixer.

Replacement of the material of the pipeline-insert from metal to a soft insert at the dry reagent dispensing unit from the hopper of the dispenser to the mixer. The goal is to have quick access for cleaning of the dry reagent inlet into the mixer unit, and to prevent the "hard" contact between the dry reagent dispenser hopper and mixer, affecting dry reagents flow readings

RADIOLOGICAL CHARACTERIZATION

Closed drums are moved to the radiation monitoring facility (6 sensors measuring EDR of gamma radiation: 5 at 10 cm from the drum surface (one on the top and one on the bottom, 3 on the side surface of the drum), 1 sensor – at a distance of 1 m from the drum surface, a gamma spectrometer with a semiconductor detector is made from high-purity germanium, used to determine the gamma-ray activity of emitting radionuclides).

The system performs the following functions:

- Measurement of the gamma background at 10 cm from the drum surface and at a distance of 1 m from it.
- Determination of the gamma activity of waste in the drum using a gamma spectrometer.

During measurement, the drum is placed on a special rotating table. The measurement data are processed and recorded. Inside the Cementation Facility, the drums are moved by the conveyor.

When the measurements are complete, the drums are loaded into a storage container (2 rows of four drums each, a total – 8 drums in one storage container). For reloading the drums, a special device for lowering the drums is used.

For the monitoring of rooms, the system of gamma sensors arranged in the rooms of the Cementation Facility is used. All sensors are integrated into a computer system, and there is a local indication and alarm.



CAUTION

Ensure the reliability of all characterization equipment (including mechanical and electronic parts) as well as the Software.

INPP had to repair semiconductor detector several times, which failed due to defects in electronics (preamplifier). INPP also found out that the software installed was outdated and not supported.



TIPS

Automate the procedure for radiological characterization to avoid the need for additional time and labour input besides the Cementation Facility operator

TRANSPORT

Hatch-wagon with the lid of transport container.

Transportation system performs the following functions:

- Waste container transportation to the Cementation Facility.
- Waste container handling within the Cementation Facility.
- Waste package transportation to from the Cementation Facility to the temporary storage.

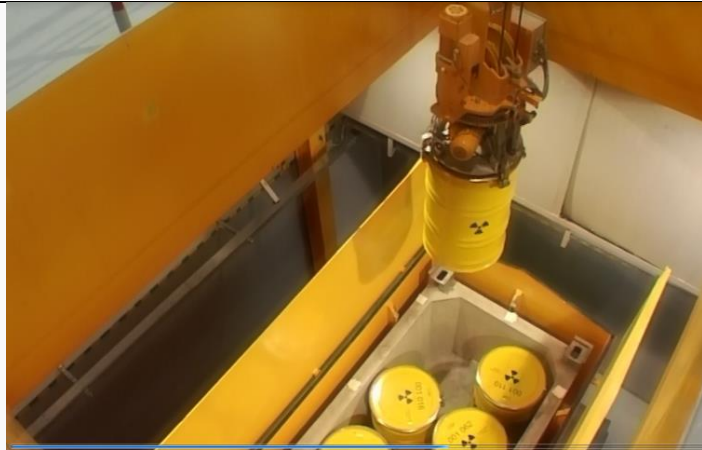

CAUTION



TIPS

The transportation system should include all necessary lifting devices, cranes, vehicles, and appropriate radiation shielding (transport container)

STORAGE

The storage facility is designed for 6,300 containers.

One 10 t crane is used to work in 3 storage directions.



CAUTION

Ensure that there are no combustible materials, lighting, etc. in the storage area at the storage facility



TIPS

The estimated duration of the movement of the radio-controlled crane in INPP is around 3 hours, and is carried out by a team of 4 people